

4

3

2

1

Panel Nut

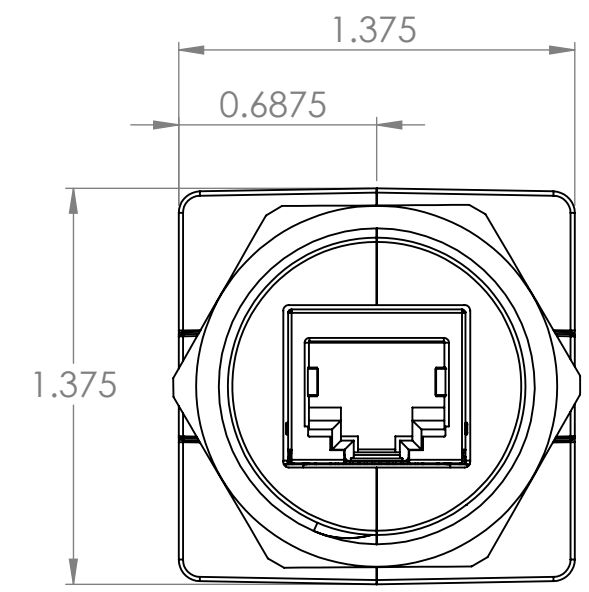
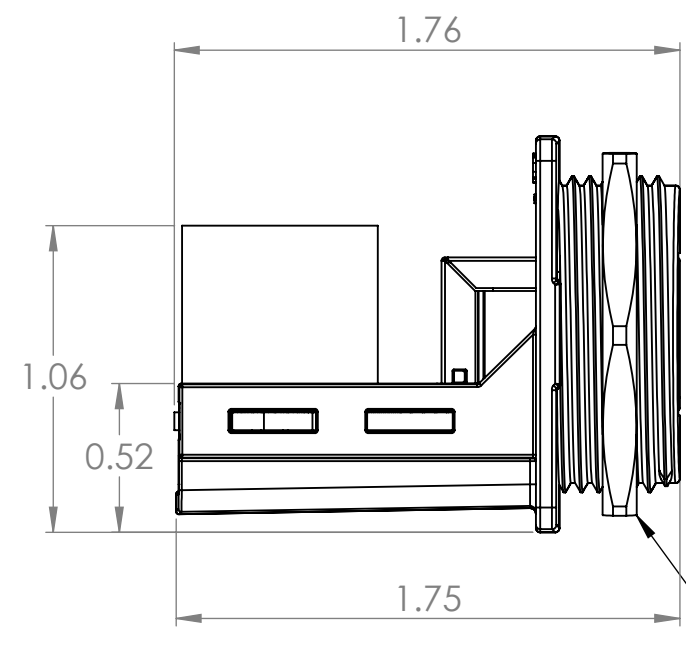
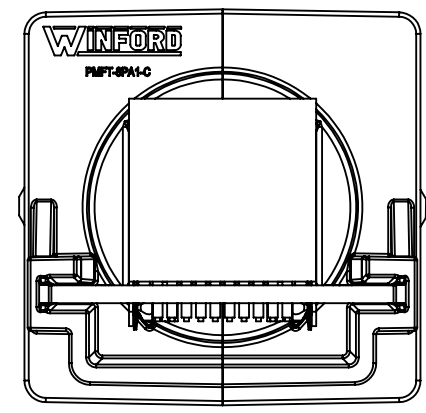
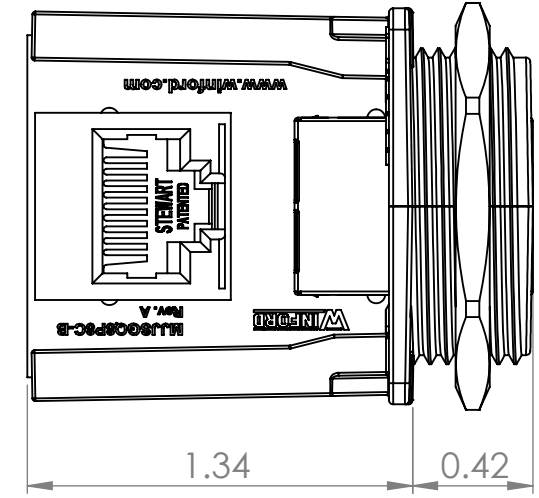
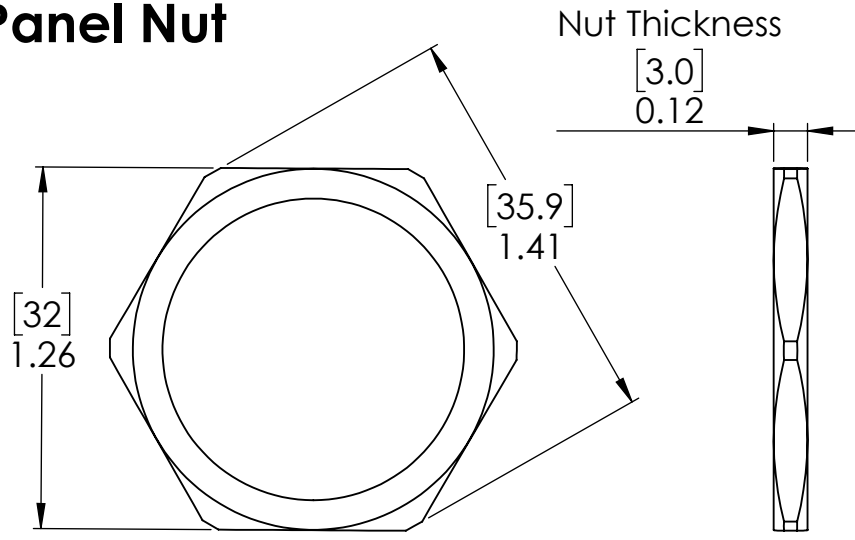

Connector Pinout

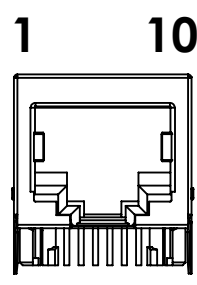

Recommended Panel Cutout

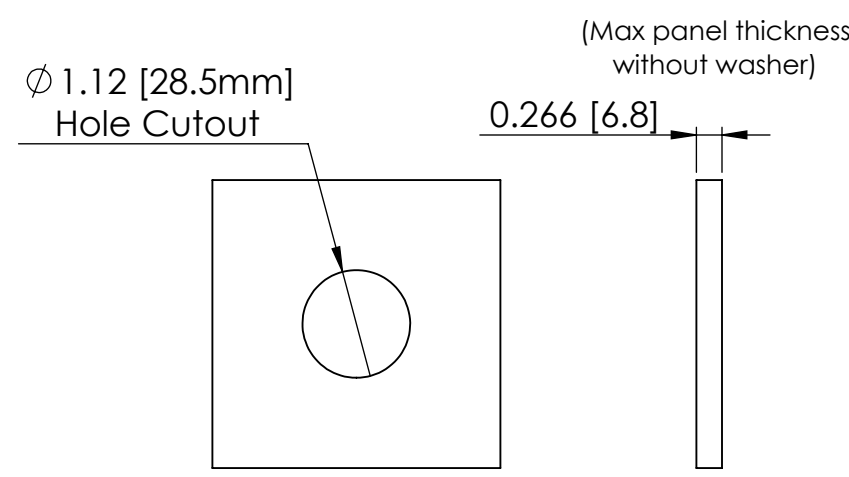

Washer not included, but available as part number: SWF-M28-B-BULK

DIM: INCH	DATE: 11/03/2023	RoHS COMPLIANT: Yes	DESCRIPTION:
 WINFORD ENGINEERING, LLC 4561 GARFIELD ROAD AUBURN, MI 48611			RJ50 10P10C Coupler, Flange Panel Mount
www.winford.com		989-671-9721	PART NUMBER (S)
			MJSSGQ10P10C-B-U
			PART REVISION
			A

4

3

2

1

B

B

A

A